

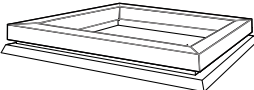





Mardome Trade

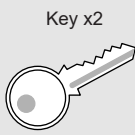

TB188

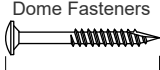
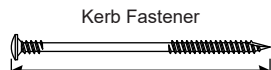
Manual Opening/Access Hatch Dome on builders upstand

Contents ! Take care when unpacking ! Check all correct parts are included and undamaged ! Only use fixings supplied				
Outer Dome 	Hinged Kerb 	Fastener Caps 	Key x2 	Worm Drive 
Dome Fasteners  <p>Length varies with product type</p>	Kerb Fastener  <p>125mm</p>	Metal Washers (if supplied) 	ACCESS HATCH ONLY	

Fixing Quantities	
Length of Nominal Dome Side (mm)	Number of fixings per side
600, 750	2
900, 1050, 1200	3
1350, 1500, 1650	4
1800, 1950	5
2100, 2250	6
2400	7

! All Health & Safety Regulations must be followed on site throughout the installation process

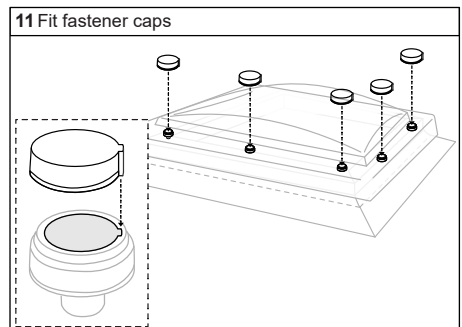
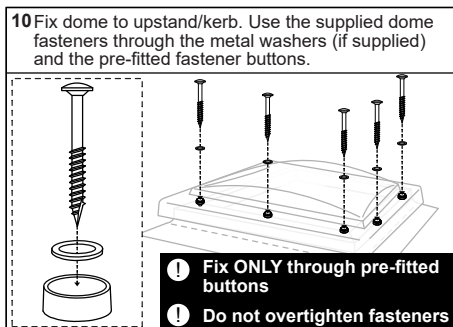
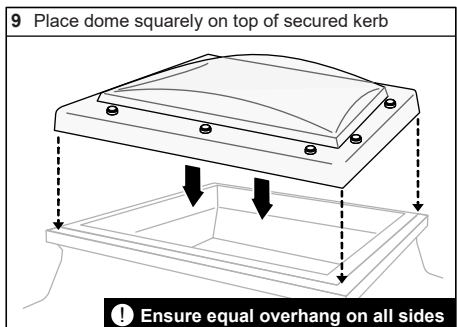
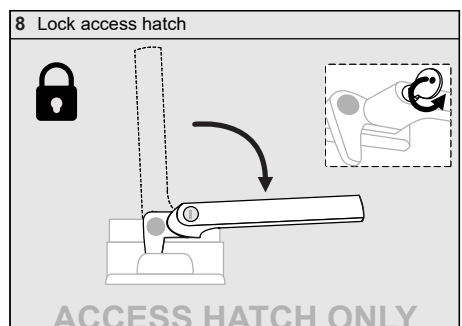
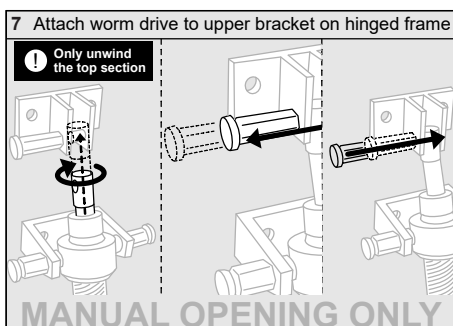
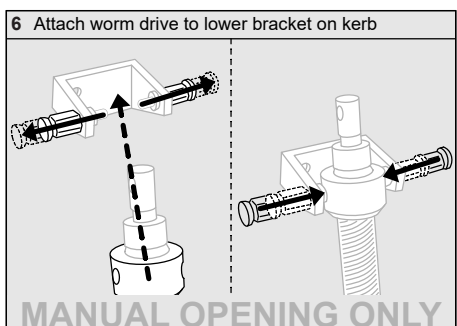
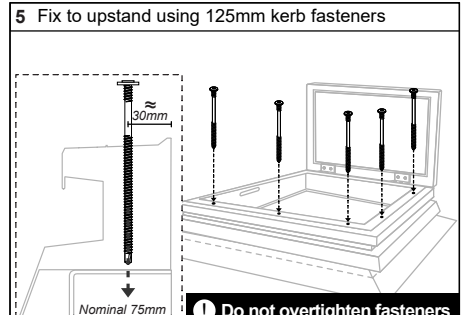
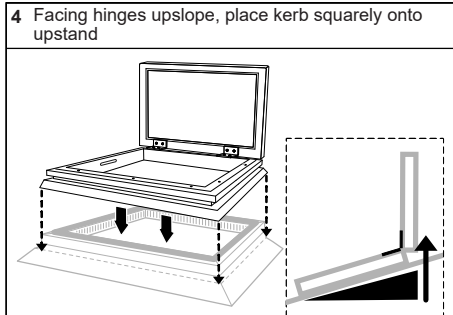
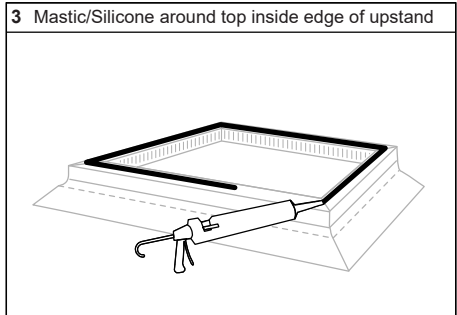
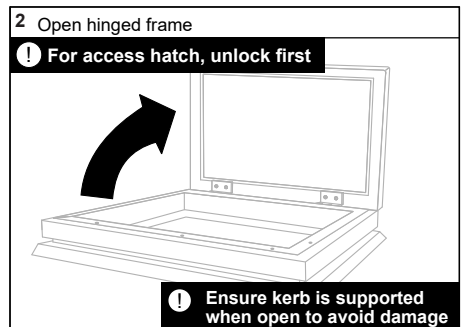
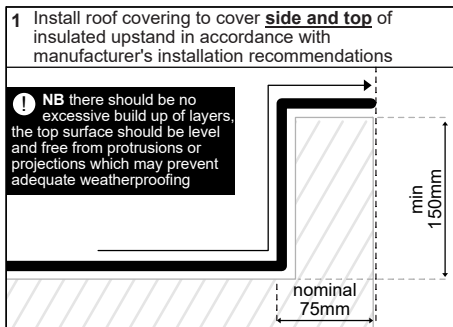
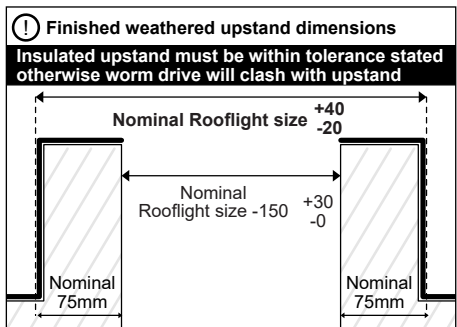

! TECHNICAL SUPPORT: For any technical information/queries please contact your supplier.

The manufacturer operates a policy of continuous product improvement, and reserves the right to alter specifications at any time without notice. Every effort has been taken to ensure all details contained in this document are correct at the time of going to press but this document should be used only as a guide and does not in any way form part of a contract or warranty. It is the customer's responsibility to ensure that the product is suitable for the actual conditions of use, which are beyond the control of the manufacturer.

Mardome Trade



TB188

Manual Opening/Access Hatch Dome on PVC kerb

Contents	⚠ Take care when unpacking	Check all correct parts are included and undamaged	Only use fixings supplied	Fixing Quantities														
Outer Dome 150mm/300mm Hinged kerb Fastener Caps Key x2 Dome Fasteners Kerb Fastener Metal Washers (if supplied)	Length varies with product type 55mm			<table border="1"> <thead> <tr> <th>Length of Nominal Dome Side (mm)</th> <th>Number of fixings per side</th> </tr> </thead> <tbody> <tr> <td>600, 750</td> <td>2</td> </tr> <tr> <td>900, 1050, 1200</td> <td>3</td> </tr> <tr> <td>1350, 1500, 1650</td> <td>4</td> </tr> <tr> <td>1800, 1950</td> <td>5</td> </tr> <tr> <td>2100, 2250</td> <td>6</td> </tr> <tr> <td>2400</td> <td>7</td> </tr> </tbody> </table>	Length of Nominal Dome Side (mm)	Number of fixings per side	600, 750	2	900, 1050, 1200	3	1350, 1500, 1650	4	1800, 1950	5	2100, 2250	6	2400	7
Length of Nominal Dome Side (mm)	Number of fixings per side																	
600, 750	2																	
900, 1050, 1200	3																	
1350, 1500, 1650	4																	
1800, 1950	5																	
2100, 2250	6																	
2400	7																	

ACCESS HATCH ONLY

⚠ All Health & Safety Regulations must be followed on site throughout the installation process

1 Mastic/Silicone around the edge of the roof opening

2 Facing hinges upslope, place kerb squarely over roof opening

3 Fix kerb to roof using 55mm kerb fasteners
Remove and retain label

⚠ See fixing quantities table
⚠ Do not overtighten fasteners

4 Install roof covering according to manufacturer's installation recommendations

If required, lightly torch roof covering.

⚠ NEVER apply direct heat or naked flame to the rooflight

⚠ Fit using instructions on kerb label

5 Terminate roof covering in accordance with instructions on retained kerb label

6 Place dome squarely on top of secured kerb

⚠ Ensure equal overhang on all sides

7 Fix dome to upstand/kerb. Use the supplied dome fasteners through the metal washers (if supplied) and the pre-fitted fastener buttons.

⚠ Fix ONLY through pre-fitted buttons
⚠ Do not overtighten fasteners

8 Fit fastener caps

Product is supplied assembled and locked shut.

The following is for information only

① Attach worm drive to lower bracket on kerb

MANUAL OPENING ONLY

① Attach worm drive to upper bracket on hinged frame

⚠ Only unwind the top section

MANUAL OPENING ONLY

① Lock access hatch

ACCESS HATCH ONLY

Ⓜ TECHNICAL SUPPORT: For any technical information/queries please contact your supplier.

The manufacturer operates a policy of continuous product improvement, and reserves the right to alter specifications at any time without notice. Every effort has been taken to ensure all details contained in this document are correct at the time of going to press but this document should be used only as a guide and does not in any way form part of a contract or warranty. It is the customer's responsibility to ensure that the product is suitable for the actual conditions of use, which are beyond the control of the manufacturer.